

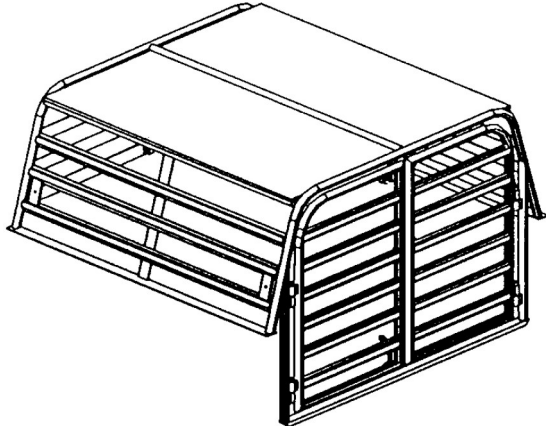

- Made entirely of strong lightweight aluminium
- Custom built to the size of your vehicle
- Variations available on request

1



Wellside Flat Top

4

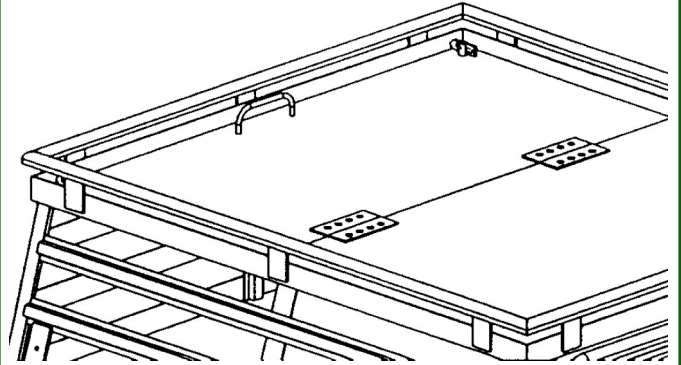

Shooting Hatch

2

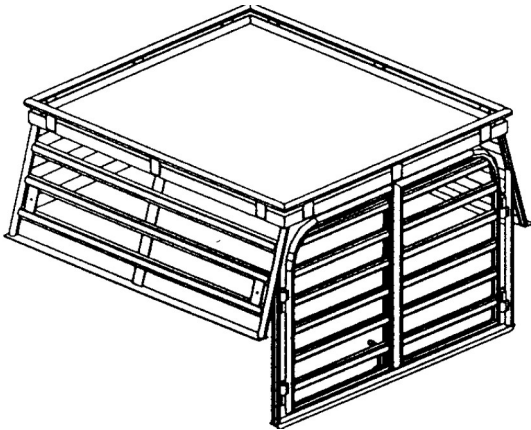

Wellside Castle Top

5

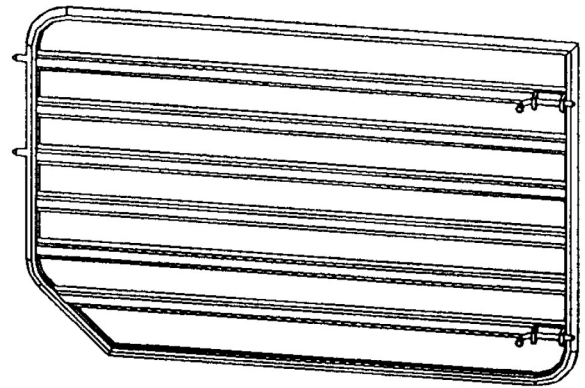

Partition (Vertical Centre)

3

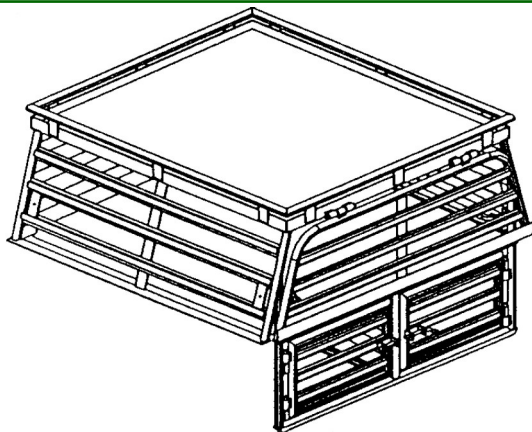

Wellside Castle Top (Tee Shelf)

6

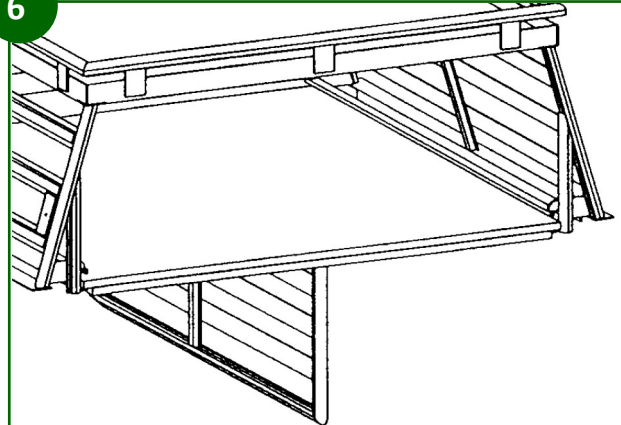

Partition (Vertical Tee Shelf)

7

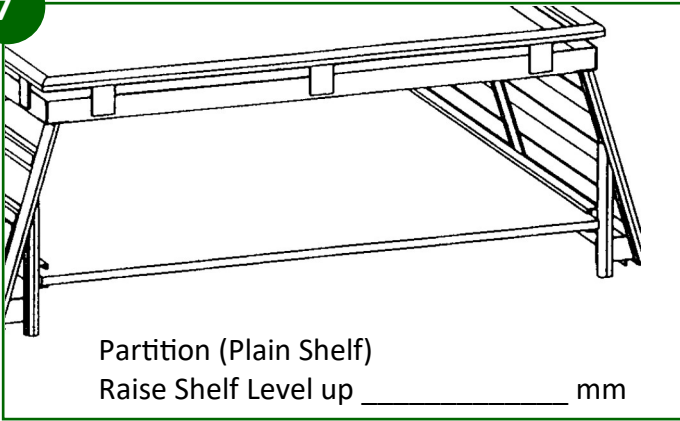

11

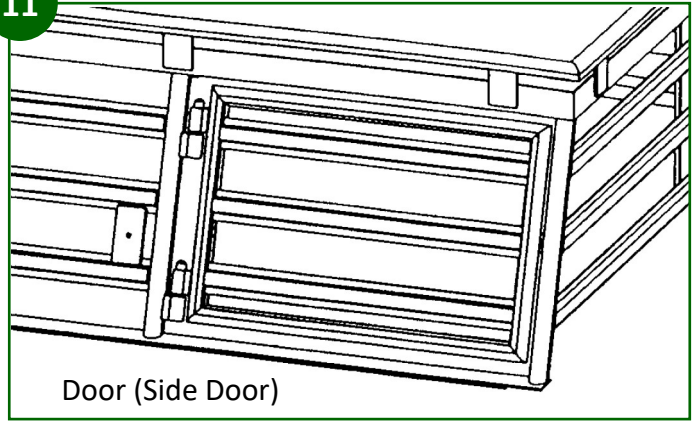

8

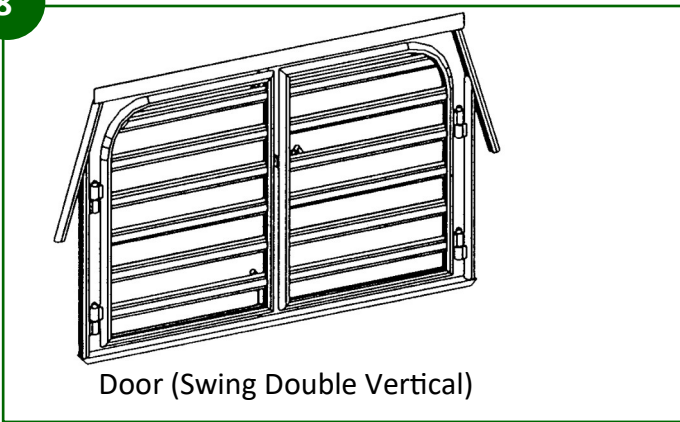

12

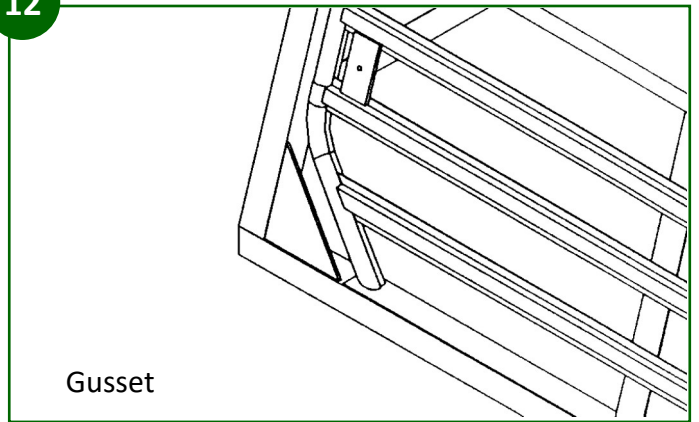

9

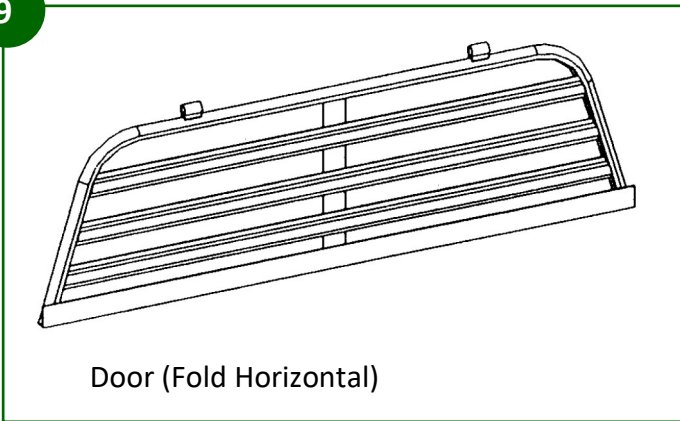

13

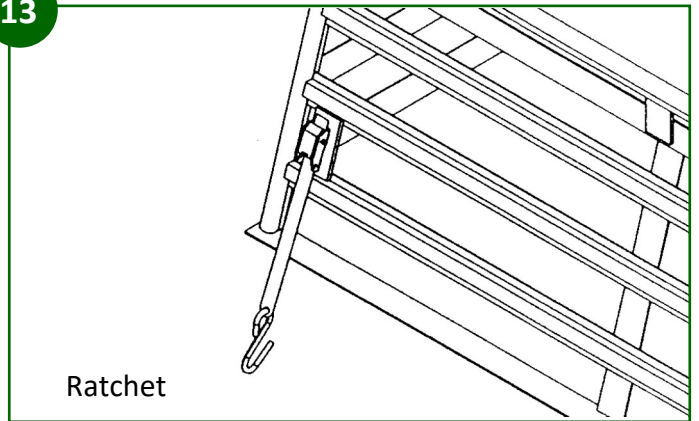

10

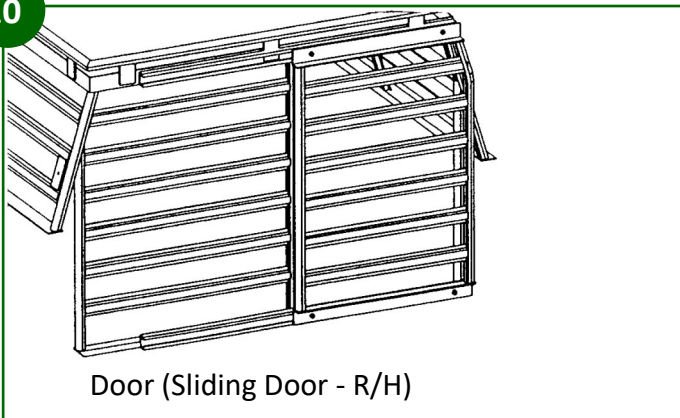

14

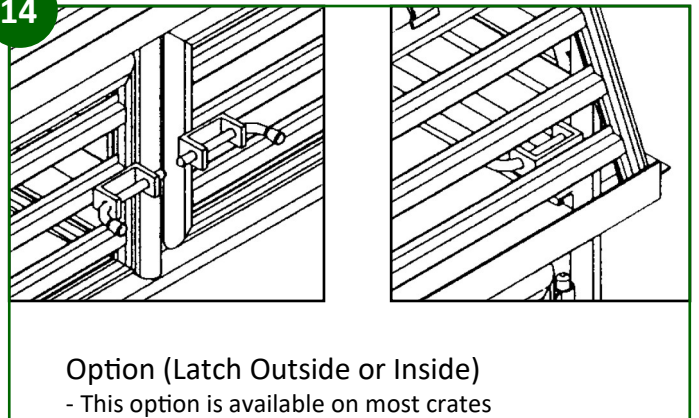

Wellside Ute Crates

Checklist for Custom Built Wellside Crates

Enquiry #	
Customer name	Contact
Phone number	
Vehicle (Make,/Model/Year/Type)	
Vehicle <input type="checkbox"/> Import OR <input type="checkbox"/> New Zealand new	
PLEASE NOTE: It is important that the measurements and specifications below are accurate. The attached template will help you take the measurements from the correct places. It would be helpful if our engineering staff could measure your vehicle at our site in Temuka.	
Actual inside deck size: Length _____ mm Width _____ mm	
Height (from side of wellside up to top of cab _____ mm	
Depth of deck _____ mm Width of the tail door inside spacing _____ mm	
NB: if vehicle has a liner this measurement is taken from the highest ridge on the liner of the deck.	
CRATE STYLE	
Flat Top - Drawing #1	
<input type="checkbox"/>	Roof ply (7mm)
<input type="checkbox"/>	No roof
Castle Top - Drawing #2	
<input type="checkbox"/>	Roof full ply (12mm)
Shooting Hatch - Drawing #4	
DIVIDER STYLE	
Vertical Centre - Drawing #5	
<input type="checkbox"/>	Bolt on
<input type="checkbox"/>	Slambolt on
<input type="checkbox"/>	Weld on
<input type="checkbox"/>	Slambolts on outside
<input type="checkbox"/>	Slambolts on inside
Vertical Tee Shelf - Drawing #6	
<input type="checkbox"/>	Slambolts on outside
<input type="checkbox"/>	Slambolts on inside
Plain Shelf - Drawing #7	
<input type="checkbox"/>	Single level shelf
<input type="checkbox"/>	Double level shelf
Provision to adjust shelf to two positions Raise shelf level up _____ mm	
GUSSETS - Drawing #12	
Please advise dimensions of gusset on template attached.	
DOOR STYLE	
T-Shelf Style Door - Drawing #3	
<input type="checkbox"/>	Slambolts on outside
<input type="checkbox"/>	Slambolts on inside
Swing Double Vertical - Drawing #8	
<input type="checkbox"/>	Post bolt on
<input type="checkbox"/>	Post fixed
Fold Horizontal Door - Drawing #9	
<input type="checkbox"/>	Top hinges pinned
<input type="checkbox"/>	Slambolts on outside
<input type="checkbox"/>	Slambolts on inside
Sliding Rear Door - Drawing #10	
<input type="checkbox"/>	Right hand side
<input type="checkbox"/>	Left hand side
<input type="checkbox"/>	Slambolts on outside
<input type="checkbox"/>	Slambolts on inside
Sliding Side Door - Drawing #11	
<input type="checkbox"/>	Top hinges pinned
<input type="checkbox"/>	Slambolts on outside
<input type="checkbox"/>	Slambolts on inside
OTHER VARIABLES	
Four Ratchets - Drawing #13	
Does the vehicle have a rope rail	
Placement of hooks (from cab end)	
Deck has liner or other	
Type _____	Thickness _____ mm
Deck has ladder rack	

All dimensions in millimetres

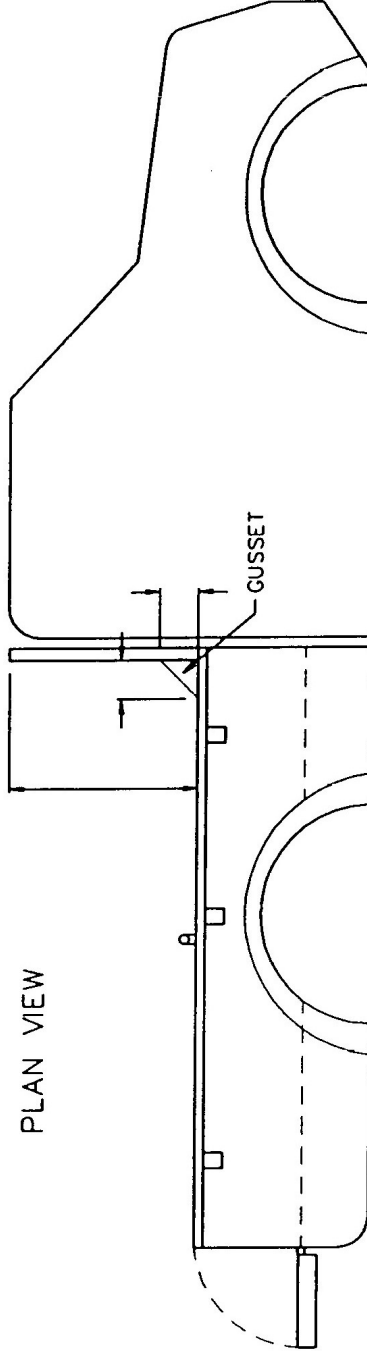
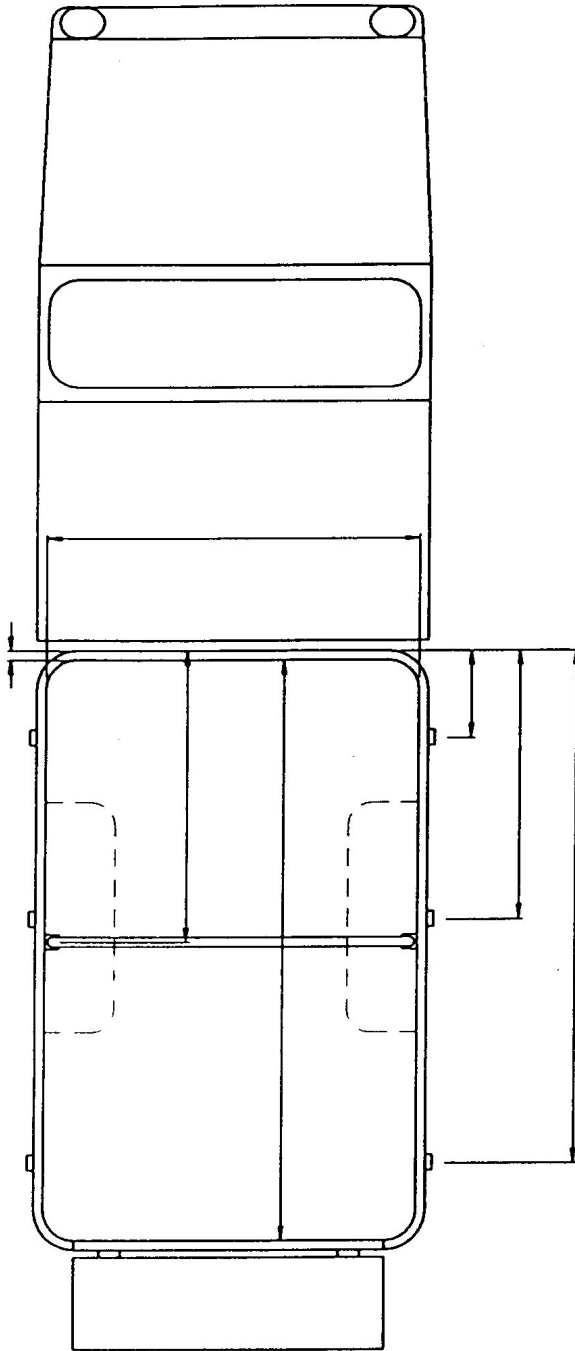

SIDE VIEW



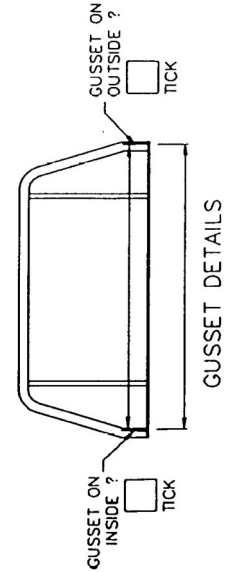
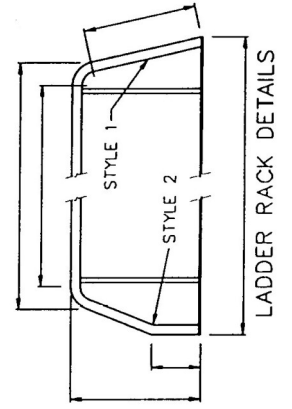

PLAN VIEW

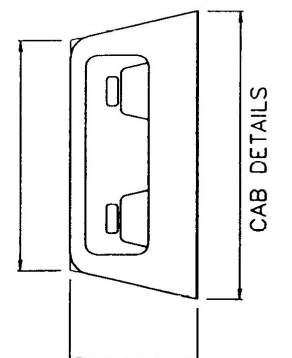
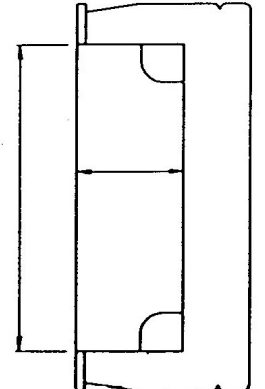

GUSSET DETAILS



CAB DETAILS

Notes: If in doubt ask!		
Scale NTS		
Date Drawn 29-01-01		
Drawn by S LOW	Approved DAVE	Date Approved 30-01-01
Dwg. No: WELLSIDE CRATE - TEMPLATE		